

# CONSTRUCTION OF A SMALL VACUUM CHAMBER FOR STUDYING A GRAVITY

*Janchai YINGPRAYOON*

*International College,  
Suan Sunandha Rajabhat University, Bangkok,  
THAILAND  
[janchai.yi@ssru.ac.th](mailto:janchai.yi@ssru.ac.th) or [dr.janchai@gmail.com](mailto:dr.janchai@gmail.com)*

## ABSTRACT

This work is to study and to construct a small vacuum chamber from a transparent plastic tube with a simple vacuum system using a big syringe. Further study is to do experiment of 2 falling objects with different weights, feather and metal ball, in the vacuum chamber. To hold these 2 objects, the magnetic system is designed to hold and release the objects at the same time. In order to pump the air out of the chamber, we used 3-way valves to let the air comes out and stop the air comes in. A low cost syringe is used to pump the air out of the chamber. In the vacuum, it is clear that a feather and a metal ball can fall in an equal way. The result of the experiment can be clearly seen by using a high speed camera. With this chamber, a value of gravity  $g$  can be measured by using a charging circuit of a capacitor. When an object is released from the top of the chamber, the charging circuit will be triggered to start charging a known-value capacitor. The voltage across the capacitor is increasing as the time passing. The charging voltage across the capacitor is increasing as a function of an exponential form of time. When the falling object reaches the floor of the chamber the micro-switch underneath is triggered to stop a charging process. By measuring a charging voltage across the capacitor, a time of a falling object can be calculated from a formula and hence the value of  $g$  can also be calculated. The measurement of this charging voltage and the time can be measured by a data logger and a hand-held calculator. The result of this method is accurate enough for the experiment in the classroom level.

**Keywords:** gravity, vacuum, free fall objects, air resistant, capacitor charging circuits, Newton's law of motion

## INTRODUCTION

A free falling object is an object that is falling under the influence of gravity. Any object that is being acted upon only by the force of gravity is said to be in a state of free fall. A free-falling object has an acceleration of  $9.8 \text{ m/s}^2$ , downward (on Earth). This numerical value for the acceleration of a free-falling object is such an important value that it is given a special name. It is known as the acceleration of gravity - the acceleration for any object moving under the sole influence of gravity. A matter of fact, this quantity known as the acceleration of gravity is such an important quantity that physicists have a special symbol to denote it - the symbol  $g$ . The numerical value for the acceleration of gravity is most accurately known as  $9.8 \text{ m/s}^2$ . There are slight variations in this numerical value (to the second decimal place) that are dependent primarily upon on altitude. An object that **falls through a vacuum** is subjected to only one external force, the gravitational force, expressed as the weight of the object. The weight equation defines the weight  $W$  to be equal to the mass of the object  $m$  times the gravitational acceleration  $g$ :

$$W = m * g \dots\dots\dots( 1 )$$

The gravitational acceleration  $g$  decreases with the square of the distance from the center of the earth. But for many practical problems, we can assume this factor to be a constant. An object that moves because of the action of gravity alone is said to be **free falling**. If the object falls through the atmosphere, there is an additional drag force acting on the object and the physics involved with the motion of the object is more complex.

The motion of any moving object is described by Newton's second law of motion, force  $F$  equals mass  $m$  times acceleration  $a$ :

$$F = m.a, \text{ in this case, } F = m.g \dots\dots\dots( 2 )$$

The **acceleration** of the object equals the gravitational acceleration. The mass, size, and shape of the object are not a factor in describing the motion of the object. So all objects, regardless of size or shape or weight, free fall with the same acceleration. In a vacuum, a metal ball falls at the same rate as a feather.

The remarkable observation that all free falling objects fall with the same acceleration was first proposed by **Galileo Galilei** nearly 400 years ago. Galileo conducted experiments using a ball on an inclined plane to determine the relationship between the time and distance traveled. He found that the distance depended on the square of the time and that the velocity increased as the ball moved down the incline. The relationship was the same regardless of the mass of the ball used in the experiment. The experiment was successful because he was using a ball for the falling object and the friction between the ball and the plane was much smaller than the gravitational force. He also used a very shallow incline, so the velocity was small and the drag on the ball was very small compared to the gravitational force.

A position versus time graph for a free-falling object is shown below.

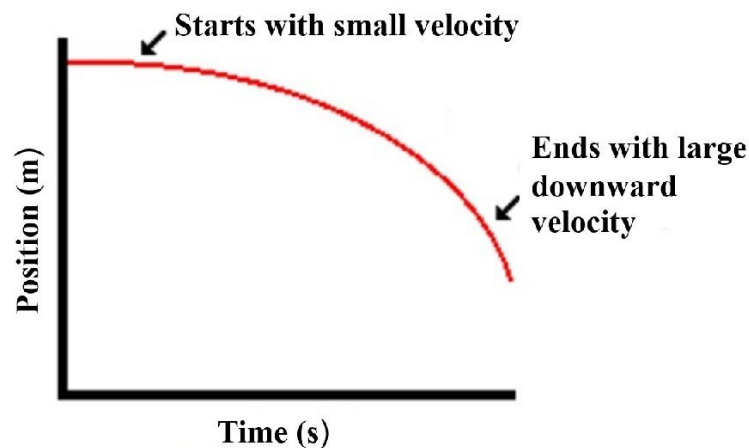

*Fig. 1. A graph position versus time*

*falling object*

*showing*

Observe that the line on the graph curves. A curved line on a position versus time graph signifies an accelerated motion. Since a free-falling object (without air resistance or drag force) is undergoing an acceleration ( $g = 9.8 \text{ m/s}^2$ ), it would be expected that its position-time graph would be in a quadratic form. A further look at the position-time graph reveals that the object starts with a small velocity (slow) and finishes with a large velocity (fast). Since the slope of any position vs. time graph is the velocity of the object, the small initial slope indicates a small initial velocity and the large final slope indicates a large final velocity. Finally, the negative slope of the line indicates a negative (i.e., downward) velocity.

A velocity versus time graph for a free-falling object is shown below.

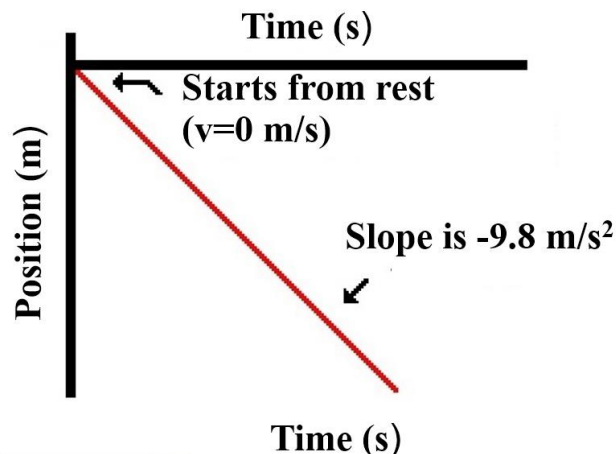

*Fig. 2. A graph showing a velocity versus time for a free-falling object*

Observe that the line on the graph is a straight, diagonal line. A diagonal line on a velocity versus time graph signifies an accelerated motion. Since a free-falling object is undergoing an acceleration ( $g = 9,8 \text{ m/s}^2$ , downward), it would be expected that its velocity-time graph would be diagonal. A further look at the velocity-time graph reveals that the object starts with a zero velocity (as read from the graph) and finishes with a large, negative velocity; that is, the object is moving in the negative direction and speeding up. An object that is moving in the negative direction and speeding up is said to have a negative acceleration. Since the slope of any velocity versus time graph is the acceleration of the object, the constant, negative slope indicates a constant, negative acceleration. This analysis of the slope on the graph is consistent with the motion of a free-falling object - an object moving with a constant acceleration of  $9.8 \text{ m/s}^2$  in the downward direction. [1], [2].

If the light free-falling object like a feather starts with zero velocity, the graph will not look like the above graph because of the air resistance or drag force. This study is to construct a simple and low-cost small vacuum chamber for doing experiment of 2 falling objects with different weights, feather and metal ball, in the vacuum chamber. This is to show that the mass, size, and shape of the object are not a factor in describing the motion of the object. So all objects, regardless of size or shape or weight, free fall with the same acceleration. In a vacuum, a metal ball falls at the same rate as a feather. Apart from this experiment, the second experiment is to determine a gravitational acceleration "g" value by using an RC charging circuit

## METHODOLOGY

### 1. Construction of a small Vacuum Chamber

The experiments showing the free-fall objects in the vacuum chamber have been done by many people. But the vacuum system for the experiment is expensive and cannot be performed in a normal classroom. In this study, we construct a low-cost and small vacuum chamber with a simple vacuum system using a big syringe.

The vacuum chamber is made from a transparent plastic tube. Both ends of the tube are close tightly. There is also outlet for air with a valve. A small piece of feather and an iron nut are used as falling objects. These two objects are hold on the top of the tube using magnetic holding lever.

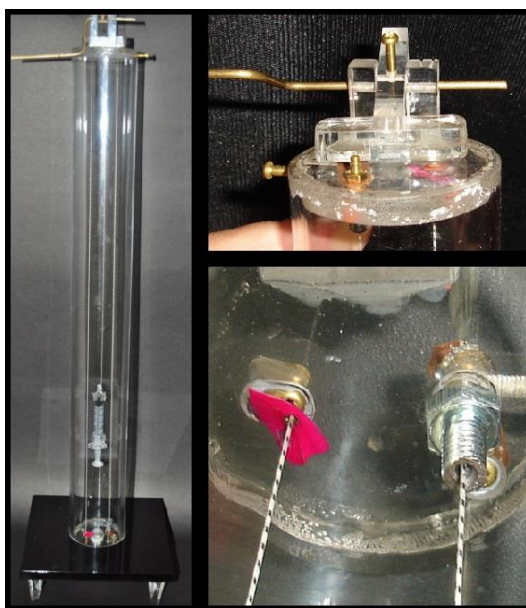

*Fig. 3. Showing the vacuum chamber made from a transparent plastic tube with outlet for air with a valve and magnetic holding lever.*

When these two objects are released simultaneously from the top of the tube, it is obviously seen that the iron nut will fall faster than a feather. The air resistance has greater effect on a feather than on a metal nut because of the weight of the objects.

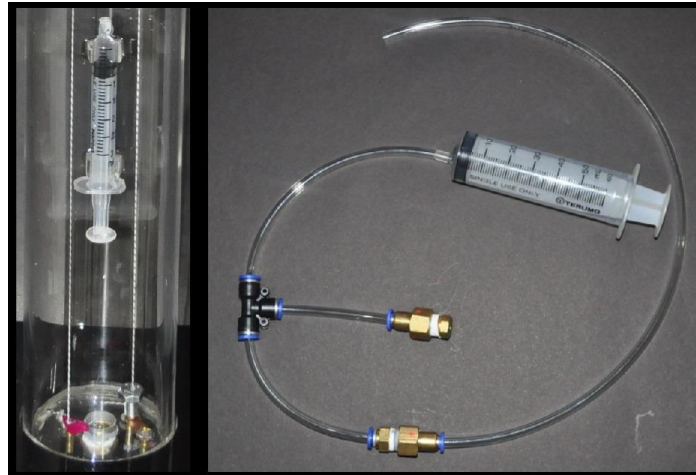

*Fig. 4. Showing a simple vacuum system using a syringe to pump the air out of the chamber and an air-tight syringe for monitoring the vacuum inside the chamber.*

In order to pump the air out of the chamber, we used 3-way valves to let the air comes out and stop the air comes in. A low cost syringe is used to pump the air out of the chamber. A vacuum condition inside the tube can be monitored by a small air-tight syringe placed in the plastic tube. The experiment can be performed by dropping the two objects from rest at the top point of the tube. The air resistance in the tube is reduced. The feather will fall faster than the result in the previous experiment. In order to measure the falling time of the objects for calculation of gravity  $g$ , a micro-key switch underneath is needed to trigger the electronic circuit of time measurement as shown in Fig. 5.

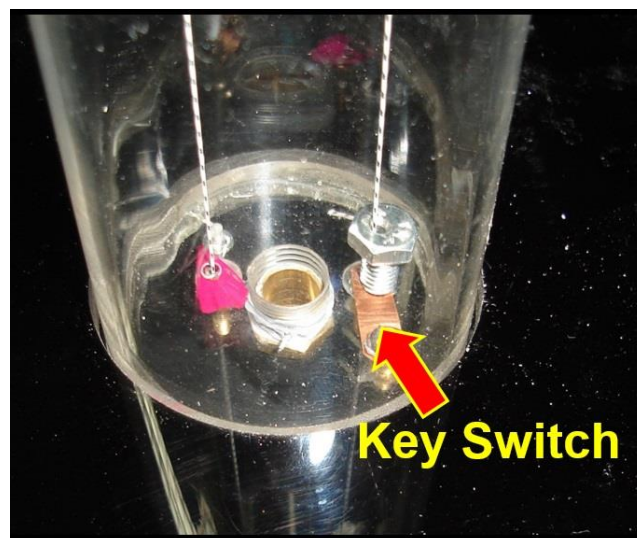

*Fig. 5. Showing a micro-key switch in the chamber for triggering the electronic circuit of time measurement*

## 2. Experiments

There are 2 experiments in this study. Observing of free-falling of metal object and a feather in vacuum chamber, and the determination of a gravitational acceleration " $g$ " value by using an RC charging circuit

### Observing of free-falling of metal object and a feather in vacuum chamber

A small piece of feather attached with a very small iron ring to be hold by a magnet and an iron nut are used as falling objects. They are big different in weights. These two objects are hold on the top of the tube using magnetic holding lever.

Firstly, these two objects were released simultaneously from the top of the tube in atmospheric pressure. The observation of the motion was done by a high speed video camera.

The second experiment was done the same way but the air in the chamber was pumped out as much as possible a big syringe. The vacuum inside the chamber was monitored by a small air-tight syringe placed in the chamber. And again, the observation of the motion in this case was also done by a high speed video camera. The video recordings from these 2 experiments were compared to confirm the effect of air resistance or drag for from air.

**Determination of a gravitational acceleration "g" value by using an RC charging circuit**

An object is falling from rest, the traveled distance S can be calculated from the following equation of motion:

$$S = \frac{1}{2}gt^2 \dots\dots\dots(4)$$

Where g is an acceleration due to gravity and t is a traveling time. Knowing the length of the chamber tube S and traveling time t, an acceleration due to gravity, g, can be calculated.

Direct measurement of time of a falling object is not accurate. The measurement of time using an RC-charging circuit is introduced.

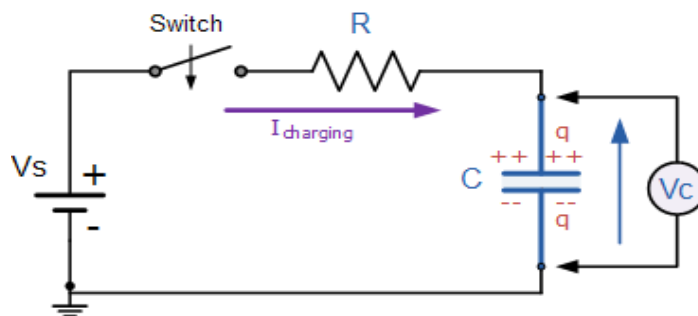

*Fig. 5. Showing a circuit diagram for RC-charging*

Instead of measuring the time, we can measure the voltage Vc as a function of time, t. Vs is a constant voltage source. If we know the values of a Resistor R and a Capacitor C, we can then find the falling time, t. The relation between Vc and charging time t is shown in the Fig. .... We can use this t to find the g from equation .....

$$V_c = V_s (1 - e^{-t/RC})$$

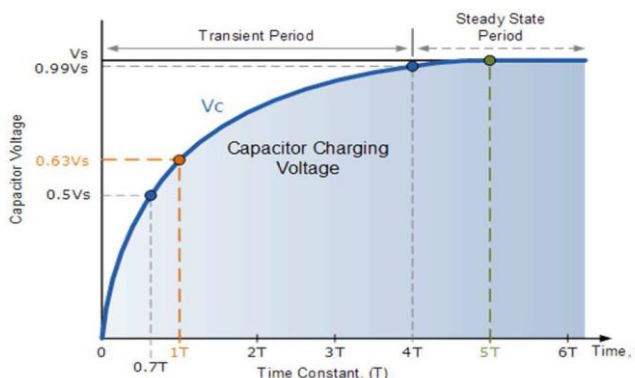

**Fig. 6.** Showing a graph of charging voltage as a function of charging time of RC circuit.

The variation of  $V_c$  as a function of time  $t$  for different  $R$  and  $C$  in the circuit can be seen by simulation using Geometer's Sketchpad [4].

The charging voltage  $V_c$  can be measured by a data logger CBL2 and displayed by a graphic calculator TI84 from Texas Instruments [3]. There is a stop key switch at the bottom of the tube. When a falling iron nut touches the switch, the voltage will drop, and the time can be measured.

## RESULTS

### Observing of free-falling of metal object and a feather in vacuum chamber

The video clips from 2 experiments clearly show that the feather and the metal nut fall almost at the same time in the vacuum. The feather falls much slower in the normal atmosphere. The big difference can be observed although the vacuum in the chamber is not a high vacuum.

### Determination of a gravitational acceleration "g" value by using an RC charging circuit

The result of this experiment can be seen on the display screen of the data logger CBL2. The starting and stopping time can be obtained from the screen. Time difference is 0.30 s as shown in the Fig..... The distance  $S$  in this experiment is 0.45 m. We can then find the value of  $g$  from the equation. ....

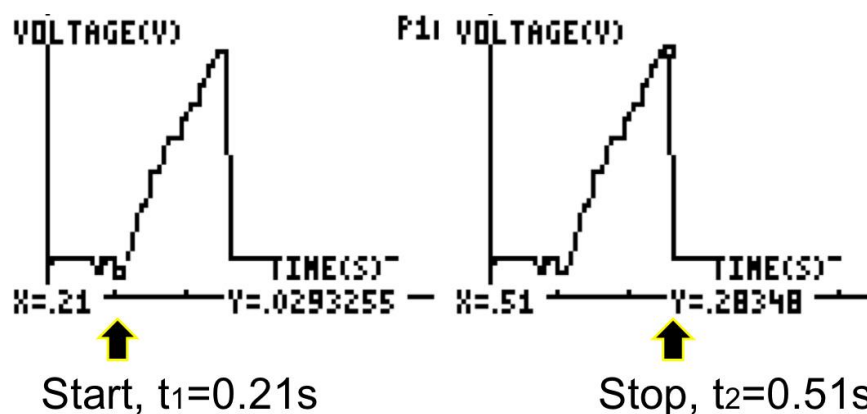

**Fig. 7.** Showing a charging voltage as a function of a time for a falling object.

$$S = \frac{1}{2}gt^2$$

$$0.45 = \frac{1}{2}g(0.30)^2$$

$$g = 10 \text{ m/s}^2$$

From all known values, we can calculate the value of an acceleration due to gravity,  $g$ . In this experiment, we get  $g = 10 \text{ m/s}^2$ .

## CONCLUSION

In order to study 2 free falling objects with different weights and shapes falling under the influence of gravity in a normal classroom is not that easy. A vacuum chamber is needed to see the effect. But the big chamber and vacuum system is expensive. By using this low cost vacuum chamber, the free falling experiment can be performed effectively. The effect of air resistance and clearly be seen. The value of an acceleration due to gravity,  $g$ , can be easily measured in a very short falling distance.

## REFERENCES

- [1] NASA Website, Motion of Free Falling Object,  
[https://www.grc.nasa.gov/WWW/k- 12/airplane/mofall.html](https://www.grc.nasa.gov/WWW/k-12/airplane/mofall.html)
- [2] The Physics Classroom,  
<http://www.physicsclassroom.com/class/1DKin/Lesson-5/Introduction>
- [3] Texas Instruments TI-84,  
<https://education.ti.com/en/products/calculators/graphing-calculators/ti-84-plus-se>.
- [4] Khairree K. (2011). A Study of Constructivist in Mathematics in Virtual Class with Moodle and The Geometer's Sketchpad (GSP). In Wei-Chi Yang, Mirosław Majewski, Tilak de Alwis and Erol Karakirk (Eds). *Proceeding of the Sixteenth Asian Technology Conference in Mathematics*. (pp. 97-106). ATCM Inc. Published, VA: USA.